

Product Description

Anthracite glass pendant with flamed blackened steel metalwork

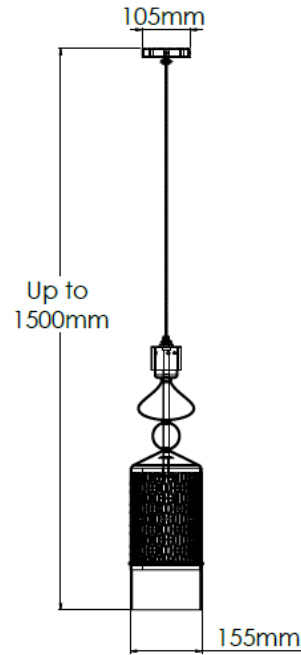

Technical Specification

MATERIAL	Glass / Brass	IP Rating	IP20
FINISH	Flamed Blackened Steel M6/FBS	HEIGHT	1500mm
LAMPHOLDER TYPE	E27 x 1	WIDTH	155mm
RECOMMENDED LAMP	GLS	DEPTH/PROJECTION	155mm
MAX WATTAGE	8W	BACK/CEILING PLATE	105mm
CERTIFICATIONS	UKCA CE	BASE DIAMETER	N/A
DIMMABLE	Mains - If lamps are compatible	WEIGHT	8kg
CLASS I / II / III	Class I	SHADE MATERIAL	Glass

Product Description

Smoke glass pendant with patinated gold-finished metalwork

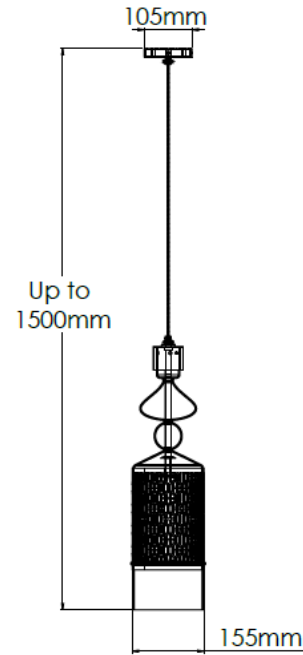

Technical Specification

MATERIAL	Glass / Brass	IP Rating	IP20
FINISH	Patinated Gold M6/PGLD	HEIGHT	1500mm
LAMPHOLDER TYPE	E27 x 1	WIDTH	155mm
RECOMMENDED LAMP	GLS	DEPTH/PROJECTION	155mm
MAX WATTAGE	8W	BACK/CEILING PLATE	105mm
CERTIFICATIONS	UKCA CE	BASE DIAMETER	N/A
DIMMABLE	Mains - If lamps are compatible	WEIGHT	8kg
CLASS I / II / III	Class I	SHADE MATERIAL	Glass